

LITHIUM POLY LINE

Lithium-Polymer Battery
LP 502030

1. Cell Data

Rating [@ 0.2C = 48 mA]	260 mAh (typical) 240 mAh (minimum)
Nominal Voltage	3.7 V
Charging Voltage	4.20 V \pm 0.05 V
Max. Charge Current	1C = 240 mA
Charging Method	<u>CCCV Standard (0.2C)</u> = 48 mA CC to 4.20 V, then CV 4.2 V for 2.0 h or 6.5 h max./12 mA cut-off; <u>CCCV Quick (1.0C)</u> = 240 mA CC to 4.20 V, then CV 4.2 V for 2.0 h or 12 mA cut-off.
Max. Continuous Discharge	1.5C = 360 mA
Discharge cut-off Voltage	3.0 V
Impedance (AC, 1kHz)	\leq 120 m Ω
Cell Dimensions & Tolerances	

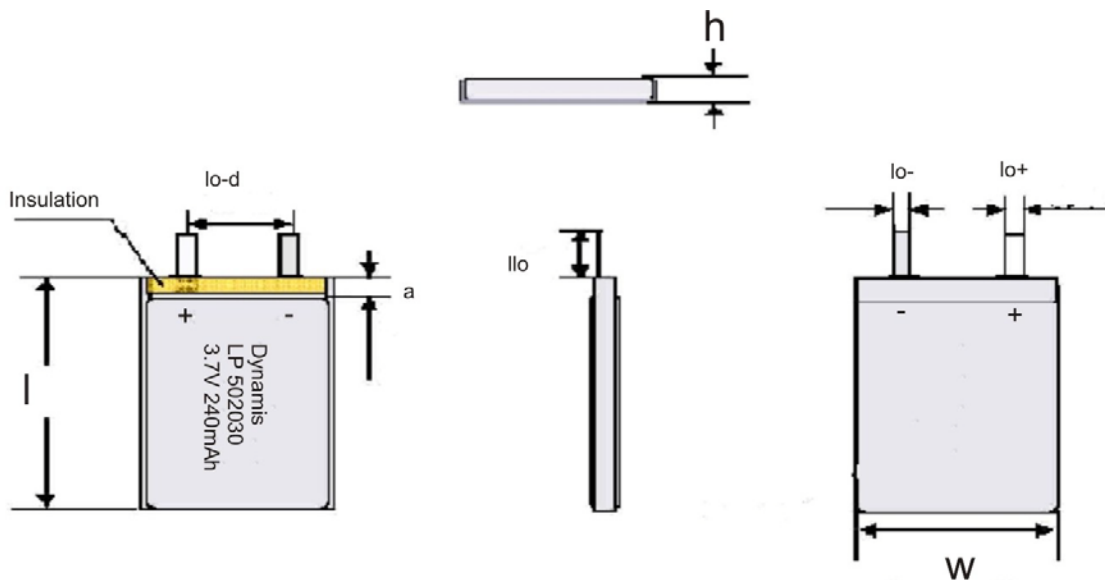

Height h: 5.0 + 0.2 mm
Width w: 20.5 \pm 0.1 mm
Length l: 30.5 \pm 0.1 mm

Detail data available upon request

Cell Weight

6.0 \pm 0.3 g

Batterien

Operating Temperatures	-10 °C to +60 °C (discharge) 0 °C to + 45 °C (charge) Operation @ 60 ± 25 % rel. humidity
Typical Storage Condition/Delivery	50 % SOC (charged status) Long Term Storage @ full charge (4.2V) not recommended
Storage Temperatures	< 1 month: -10 °C to +45 °C < 6 months: -10 °C to +35 °C
Energy Content	0.89 Wh

2. Battery Performance

2.1 Electrical Performance

All ratings are measured after Standard Charge under Standard Test Conditions (Sec. 4)

Standard Charge	The cell shall be charged at a constant current of 48 mA (0.2C) to a charge voltage of 4.2 V and then followed by a constant voltage charge of 4.2 V for either 2.0 hours time or reach of 12 mA charge current as cut-off criteria.
Rated Capacity (RC)	240 mAh minimum [discharge current = 48 mA (C ₅), cut-off = 3.0 V]
Very Low Temperature Capacity	appr. 60 % of RC [discharge current = 48 mA, ambient temperature = -10 ± 2 ° C, cut-off = 3.0 V]
High Temperature Capacity	appr. 90 % of RC [discharge current = 48 mA, ambient temperature = +55 ± 2 ° C, cut-off = 3.0 V]
Storage Characteristics 25 °C	Capacity Retention 85 % for 0.2C discharge [Standard Charge plus 30 days @ 25 ± 5 °C] Capacity Recovery ≥ 90 % for 0.2C discharge [after 3 cycles as max. value]
Storage Characteristics 60 °C	Capacity Retention 55-60 % for 0.2C discharge [Standard Charge plus 7 days @ 60 °C] Capacity Recovery ≥ 80 % for 0.2C discharge [after 3 cycles as max. value]
Long Term Storage (Self discharge)	Store 50% SOC cell at RT for 365 days; after 3 cycles 0.5C charge/0.2C discharge Capacity Recovery ≥ 80 % of RC

Cycle Life (norm.)

Charge 0.5C/12 mA cut-off + 0.5C discharge to 3.0 V
Rest between cycles 30 min, 25 °C

> after 300 cycles min. 80 % of initial Capacity

2.2 Mechanical Performance & Safety Testing

All results are obtained after Standard Charge under Standard Test Conditions (Sec. 4)

2.2.1 Vibration Test

Result: No Leakage, no Fire
Condition: 3 perpendicular axis;
10 Hz to 55 Hz at 1 Hz/min rate
Amplitude: 0.38 mm for 10-30 Hz, 0.19 mm for 30 to 55 Hz

2.2.2 Short Circuit Test

Result: No Fire, No Explosion, max. cell Temperature below 150 °C
Condition: Short circuit with connector R < 100 mΩ, monitor cell temperature until peak reached and cooled to peak temperature minus 10 °C.

2.2.3 Deep Discharge Test

Result: No Fire, No Explosion
Condition: 1C discharge for 2.5 h

2.2.4 Drop Test

Result: No Explosion, No Fire, No Leakage
Condition: 2x drop from height of 1 m onto concrete ground

2.2.5 Humidity Exposure Test

Result: More than 60 % of initial 1C capacity (to 3.0 V)
Condition: After Standard Charge, Store for 48 h @ 40 °C and 90-95 % rel. humidity, Discharge after 2 h at 1C to 3.0 V

2.2.6 Impact Test

Result: No Explosion, No Fire
Condition: 10 kg weight drops from 1 m height on 56 mm diameter bar on top of cell, bar not fixed

2.2.7 Nail Test

Result: No Explosion, No Fire
Condition: Nail w/ 3 mm diameter punctured through flat surface of cell, remain 2 h

2.2.8 Crush Test

Result: No Explosion, No Fire
Condition: Placed between 2 flat plates with 13 kN applied force, maintained for 30 min.

3. Other Related Documents

DYNAMIS strongly advises to follow the "Handling Precautions and Guideline for Lithium Polymer (LP) batteries".

Any figures included in this specification deviating from those in the a.m. guidelines are prevailing those in the guidelines.

4. Standard Test Conditions

New cells are tested within 1 month after shipment from the factory and the cells shall not be cycled for more than 5 times before testing.

All tests in this specification shall be conducted at an ambient temperature of 25 ± 5 °C and a rel. humidity of 60 ± 25 % unless otherwise specified.

The requirements for precision and maximum tolerances of the testing equipment can be provided by DYNAMIS upon request.

5. Particular Safety Precautions for Lithium Polymer cells

- Covered Aluminum pouch may be easily damaged by sharp tools of any kind, needles, tabs with sharp edges or similar. Storage and handling of LiPo cells must be without these tools or parts
- No mechanical deformation of any kind shall be allowed to LiPo cells or batteries
- Damaged cells shall not be used under any condition

6. Particular Battery Pack Assembly Precautions

- Ultrasonic welding or spot welding are recommended for LiPo tab connection

Recommended conditions:

- > Solder Iron temperature controlled and ESD safe
- > Max. solder temperature is 350 °C
- > Max. solder duration is 3 seconds
- > Max. number of solder actions is 5, cooling to RT between is recommended to prevent too much heat application

- No shear or other force is to be applied to LiPo cell tabs

* The information (subject to change without notice) contained in this document is for reference only and should not be used as a basis for product guaranty or warranty. For applications other than those described here, please consult your nearest DYNAMIS Sales or Marketing Office or Distributors.